

HL Y12AA
COMPRESSOR

TECHNICAL
SPECIFICATION
(220-240V~50Hz)

CHANGHONG HUAYI COMPRESSOR CO., LTD.

INDEX

	page
1、 Compressor Type.....	2
2、 Performance Data.....	2
3、 Running Condition	2
4、 Compressor Mechanical Information	3
5、 Compressor Shape	3
6、 Wiring Diagram	4
7、 Fixing of mounting bracket and cabinet base.....	4
8、 Starter relay and Thermal protector.....	5
9、 Delivery State	6
10、 Package、 Storage and Transportation.....	6
11、 Technical Items	7

1. Compressor Type

Compressor model	HLY12AA
Rated voltage/frequency	220-240V~50Hz
Refrigerant	R600a
Application	Low back pressure (LBP)
Cooling method	Static Cooling
Control device	Capillary tube
Motor type	RSCR (PTC)
Capacitor	4 μ F

2. Performance Data

Displ.(cm ³)	Capacity(W) $\geq 95\%$	Inp.Pow.(W) $\leq 115\%$	Rated Current(A) $\leq 110\%$	COP (W/W) $\geq 95\%$
11.3	197	121	0.66	1.65

Testing condition:

Test conditions	LBP
	ASHRAE
Evaporating Temp.	-23.3°C
Ambient Temp.	32.2°C
Condensing Temp.	54.4°C
Suction Temp.	32.2°C
Subcooling Temp.	32.2°C

3. Running Condition

Ambient temp.	10~43°C
Evaporating temp.	-35~-15°C
Voltage range	187~254V
Max. condensing temp.	65°C
Max. winding temp.	130°C
Max. shell temp.	95°C
Max. discharge temp.	110°C

4. Compressor Mechanical Information

Oil type	Mineral
Oil charged	180±10ml
Diameter of suction tube (I.D.)	$\Phi 6.1^{+0.1}_0$ mm
Diameter of discharge tube(I.D.)	$\Phi 4.9^{+0.1}_0$ mm
Diameter of process tube (I.D.)	$\Phi 6.1^{+0.1}_0$ mm
Material of suction tube, process tube and discharge tube	copper tube
Compressor noise	≤41dB(A)
Vibration	≤0.8m/s ²

5. Compressor Shape (connections on suction and process can not be inverted)

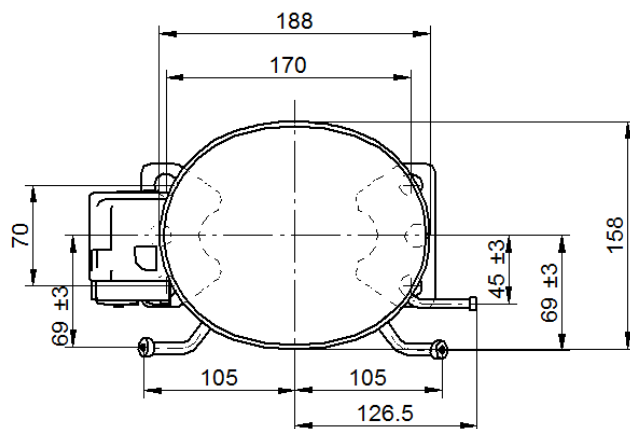
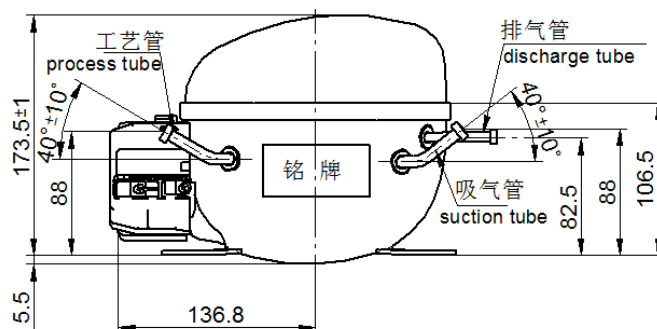

6. Wiring Diagram

RSCR:

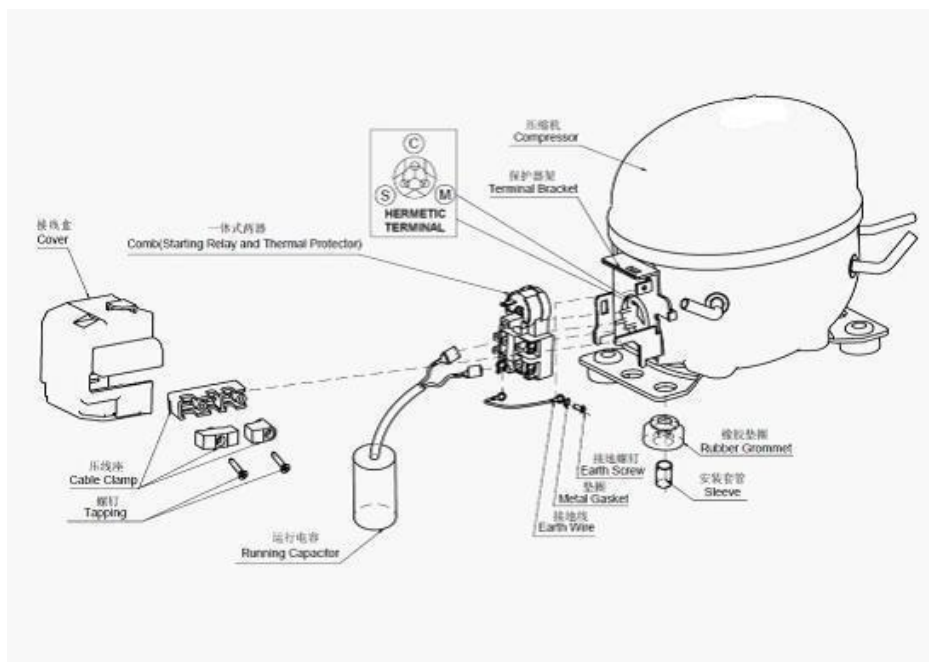
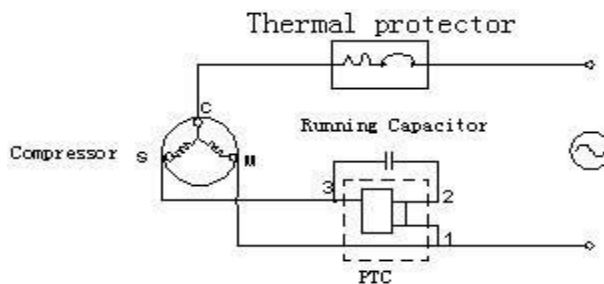

Note: Each of the starting relay、 the thermal protector、 the spring tap、 the terminal cover and the screw assembly is separately provided by our company.

7. Fixing Of Mounting Bracket And Cabinet Base

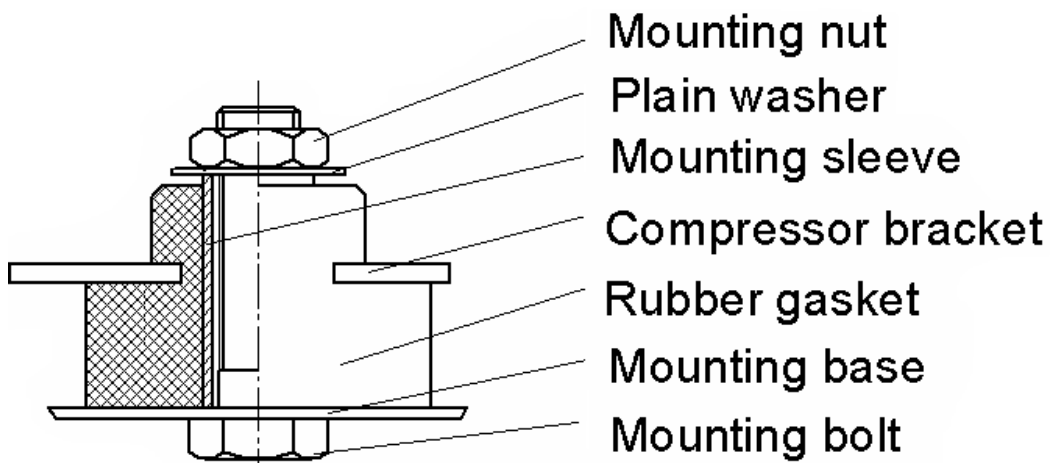

8. starter relay and Thermal protector

Comb modle: QP3-12A/B52-120

8.1 Starting relay

Model: QP3-12A

Type:Starting relay

max current: 8A

max working voltage:350 V

Flammability: Anti-flammability

8.2 Thermal protector

Model: **B52-120**

Compressor model		HLY12AA
Thermal Protector	Max.T.C Amp.(25°C) A	5.2
	Trip time S	6~14
	Reset time S	50~150
	Open temp. ±5°C	120
	Close temp. ±9°C	61
	Min. T.C. Amp.(70°C) A	0.90~1.40

Flammability:Anti-flammability
flammability

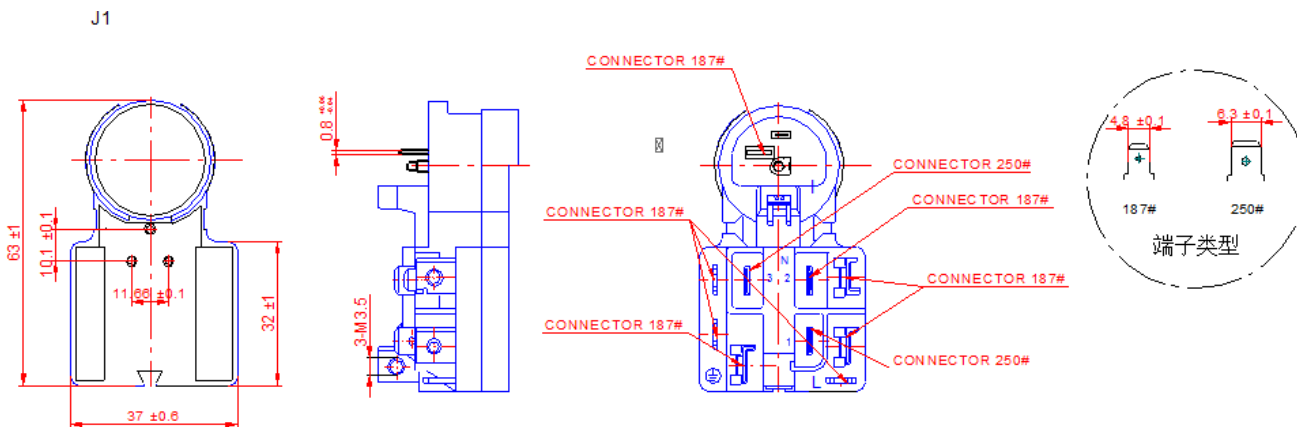

9. Delivery State

No.	Name	Model	Quantity	CODE
1.	Compressor	HLY12AA	1 pcs	
2.	MOUNTING ACCESSORIES			
2.1.	Rubber Gasket		4 pcs	E.24.12.201
2.2.	Plain Washer		4 pcs	CTE983-2
2.3.	Mounting Sleeve		4 pcs	CTE943-2
2.4.	Mounting Bolt	M6×30	4 pcs	GB5781-86
2.5	Mounting Nut	M6	4 pcs	GB6170-86
3.	ELECTRICAL ACCESSORIES			
3.1.	Starting Relay and Thermal Protector	QP3-12A/B52-120	1 pcs	J1
3.2	Terminal Cover	E. 24. 01. 59	1 pcs	
3.3	Screw Assembly		1 pcs	E.14.24.201
3.4	Running capacitor	4 μ F	1 pcs	
3.5	Earth wire		1 pcs	E.24.05.281

Notes: 1. All electrical parts and equipment assembly are supplied separately, not installed on the compressor.

2. All electrical parts and equipment assembly according to Delivery states are all provided by our company.

10. Package、Storage and Transportation

Package type	unreusable
Quantity	72pcs/box
Transportation	By truck or train
Storage	Max. 2 layers
Volume	m ³ 0.88
Dimension: length×width×height (mm)	1120×820×960
Main components	Wooden supporter、foam divider、plastic sheet、cardboard cover、wrapping
Movement	Keep the compressor in normal or vertical position (a short time before compressor installed in the refrigerator).
Trans. test requirement	No allowable compressor's damage and performance loss.

11. Technical Items

1. After pulling off rubber plugs from the compressor tubes, please connect the compressor to the refrigeration system within 5 minutes. It is advisable to take off the first plug from process tube. No dust or humidity in the air is permitted to enter the compressor.
2. Earth connection should be fixed permanently and reliably.
3. The compressor must be mounted horizontally without tilting an angle more than 5° .
4. Maximum operating ambient temperature is at 43°C .
5. When the compressor starts, balance pressure inside refrigeration system must be less than 0.3Mpa (Absolute).
6. The compressor must not be restarted unless at an interval of more than 5 minutes.
7. Please keep the compressor always vertically and never upset it during transportation while avoiding any vibration and shock.
8. Please store the compressor in a dry and ventilated place and keep it away from any humidity.
9. Please follow the transportation warning marks on the package for layer limitation. Do not roll the whole packages when loading or unloading.
10. Storage expiry is 6 months from the date of production. If it expired, please check the nitrogen pressure inside compressor and recharge it when it is necessary.